

BELT TEST REQUIREMENTS

Red Belt

1. FORMS: “Taegeuk Yook Jang” *** (Adults do both forms “Taegeuk Chil Jang”)*
2. BASIC STANCES & HAND TECHNIQUES:
 - A) Blocks:
 - Double Low Knife Hand
 - Palm Middle Block
 - Scissor Block
 - Double Arm Spread Block
 - Lower Section Axe Block
 - High Outer Middle Block
 - B) Stances: Tiger Stance
 - C) Strikes: Upper Section Side Back Fist Strike
 - Double Upper Cut Strike
 - Upper Palm Middle Block with Back Fist Strike
 - Knee Strike
3. IL BO GYORUGY (1 STEP SPARRING)
 - Create your own – Striking Techniques ONLY – Minimum of 10 examples
4. ANJA GYORUGY 1-4 (KNEE SPARRING)
 1. Lift right knee/Left hand knife block/Right hand middle punch
 - Left hand low punch
 - Right hand face punch
 2. Lift right knee/Left hand knife block/Right hand knife hand neck strike
 - Move right leg to opposite side of opponent’s right leg/push on shoulder to knock down
 - Right hand face punch
 3. Turn toward the right and lean backwards placing two hands on mat
 - Left foot side kick to face
 4. Lift right knee/Right arm Middle Inner Block
 - Right arm elbow strike
 - Right hand back fist strike to face
5. JAIU GYORUGY (FREE SPARRING):
 - Against both 1 & 2 opponents
6. KYOPA (BOARD BREAKING):
 - Spinning Hook Kick and/or combinations of other kicks
7. QUESTIONS: All information given on the white – red question sheets

Tae Geuk Yook Jang

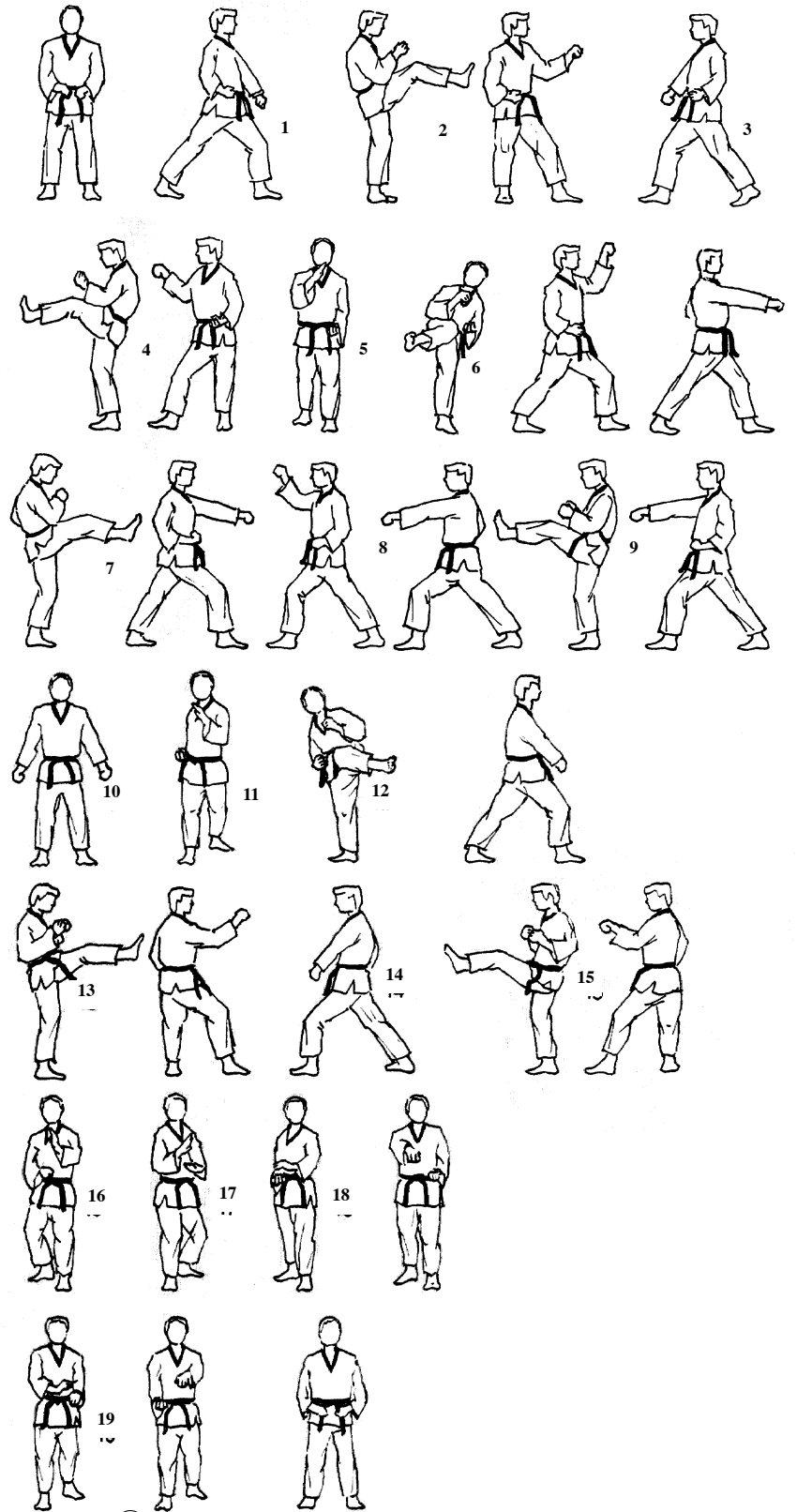
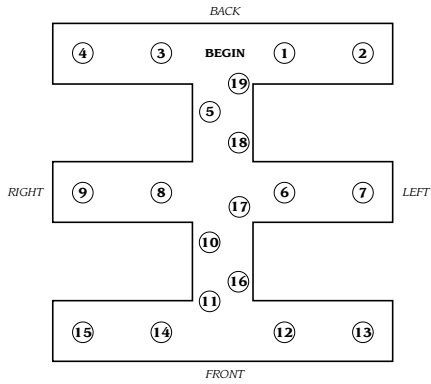

Tae Geuk Chil Jang

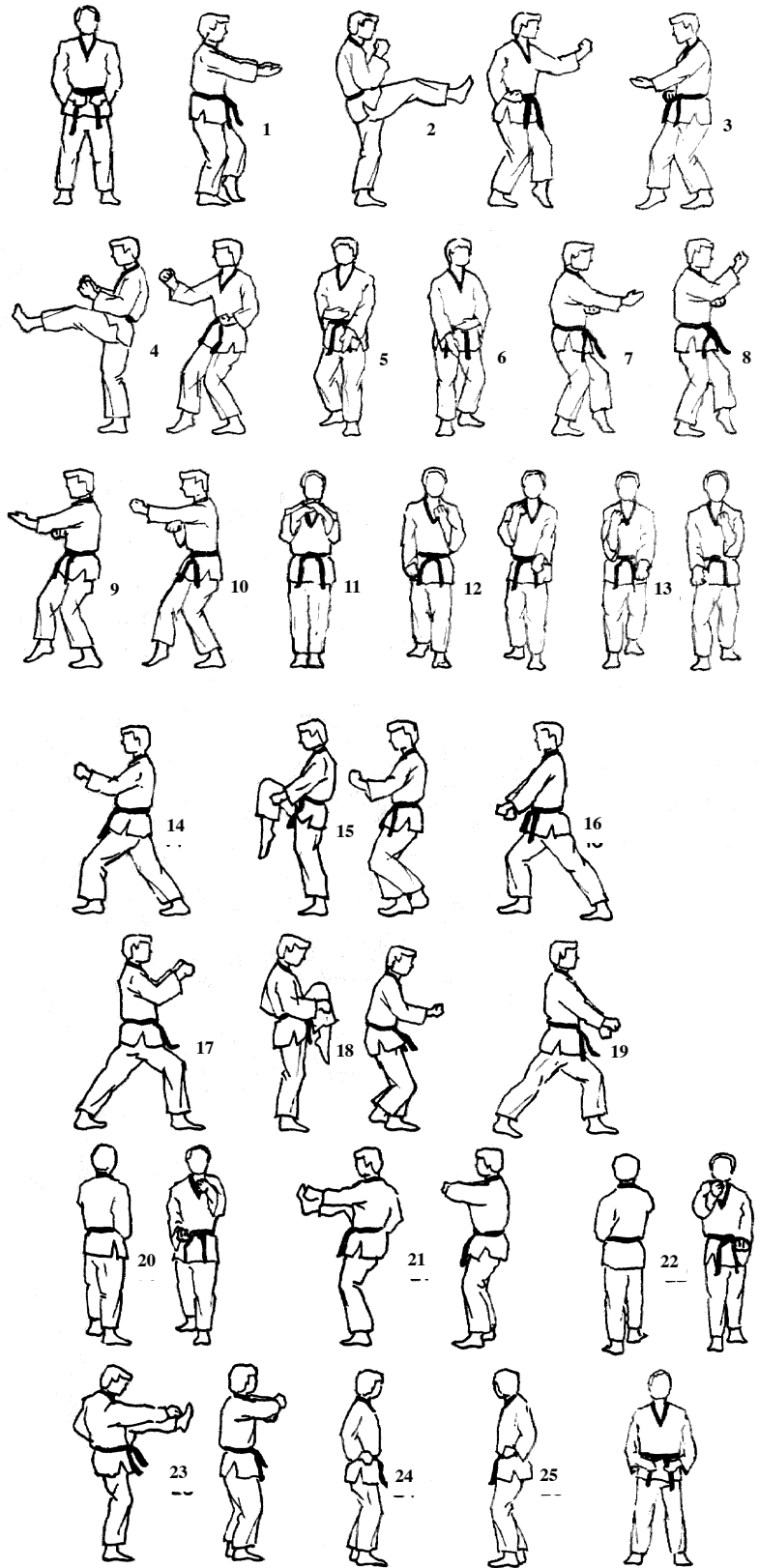
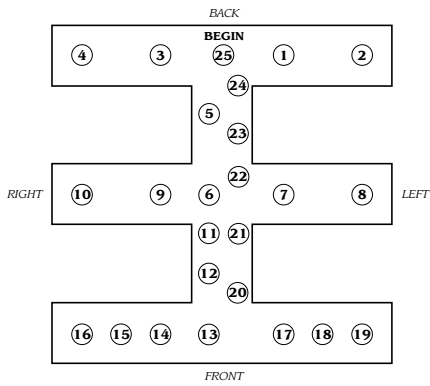

Red Belt Questions

What is the meaning of the Red Belt?

The red belt stands for fire – Use caution when you practice Taekwondo.

1. What is the meaning of Taegeuk Yook Jang?
The sixth Taegeuk form – represents Water
2. What is the meaning of Taegeuk Chil Jang?
The seventh Taegeuk form – represents Mountains
3. Give three examples of self discipline:
A) I limit how much junk food I eat
B) I stop and think before I act
C) I wait for the teacher to finish talking before asking for help

Red Belt Self Defense Curriculum *** (Adults Only)*

1. Attacker grab opponent from behind, under opponent's arms, clasping hands. Right hand reaches under own left arm and grabs attacker's left sleeve. Left elbow strike to attacker's face. Left leg behind attacker, swing left arm across opponent's chest/face, pushing attacker backwards.
2. Attacker grab opponent from behind, under opponent's arms, clasping hands. Right hand reaches under own left arm and grabs attacker's left sleeve. Left elbow strike to attacker's face (same as 1). Reach with left arm around back of attacker's neck and grab shoulder. Step back with body into attacker's body and perform hip throw.
3. Attacker reaches around neck with right arm. Left hand punch. Right hand across body into bicep to stop punch. With left hand, reach behind attacker's left arm and grab Dobok and pull back. Right hand grabs attacker's right wrist. Stand up, turning body 90 degrees away from attacker. Step back with left foot and raise right arm. Bring attacker's right arm behind attacker's back and apply upward pressure.
4. Attacker reaches around neck with right arm and grab own fist. With right hand, grab attacker's choke arm, while left arm goes behind and over attacker's right shoulder. Push attacker's chin away from body.