

# **BELT TEST REQUIREMENTS**

## **Purple Belt**

1. FORM: “Taegeuk Sa Jang”
2. BASIC STANCES & HAND TECHNIQUES:
  - A) Blocks:
    1. Palm block
    2. Knife hand rising block
    3. Outer arm middle block
    4. Double knife hand middle block
  - B) Strikes:
    1. Middle target spear hand strike
    2. High section back fist strike
3. IL BO GYORUGY (1 STEP SPARRING)
  1. Move right foot out into horse riding stance/left hand knife block/right hand middle punch  
Left hand low punch  
Right hand high punch
  2. Move right foot out into horse riding stance/left hand knife block/right hand neck strike  
Move right foot to outside opponent’s right leg/step in close to opponent's hip. Then grab  
opponent’s wrist with left hand/push on opponent’s left shoulder  
Knock them down (don’t release wrist)  
Punch to head with right
  3. Right foot crescent kick to opponent’s punch  
Before your right foot touches the ground, turn body and side kick opponent to ribs
  4. Right foot step forward/middle inner block opponent’s punch  
Right elbow strike to ribs  
Turn body/left elbow strike to ribs  
Left hand back fist strike to face  
Sweep opponent’s right leg with your right leg and knock down  
Right leg side kick to head
4. JAIU GYORUGY (FREE SPARRING)
5. KYOPA (BOARD BREAKING): Back Kick
6. QUESTIONS: All information given on the white – purple question sheets

# Tae Geuk Sa Jang

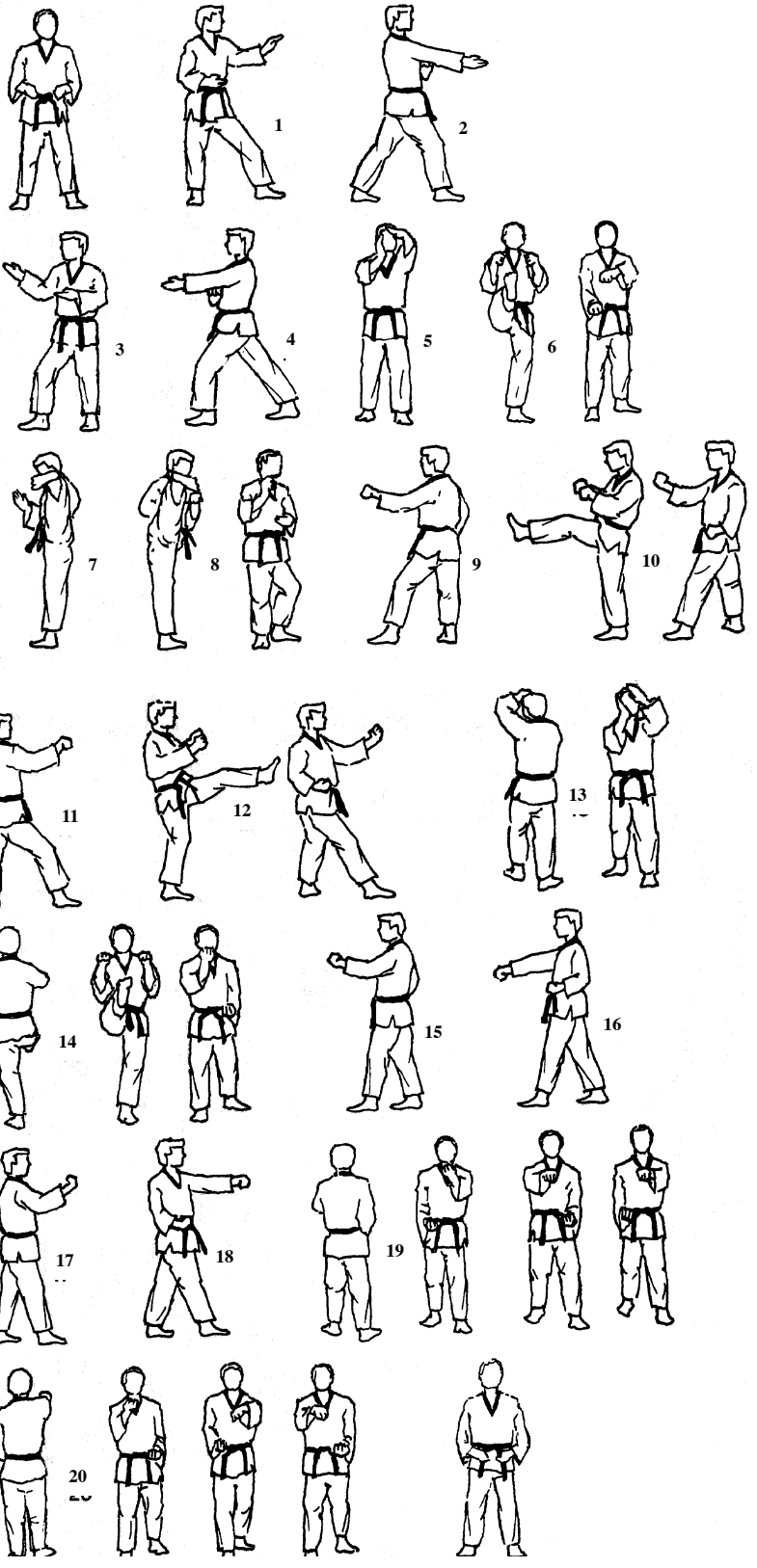
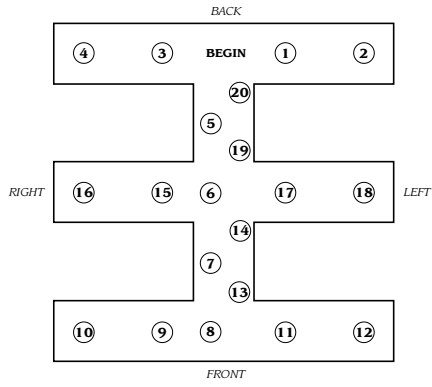

## Purple Belt Questions

What is the meaning of the purple belt?

The purple belt represents power, the royal color of majesty.

What is the meaning of Taegeuk Sah Jang?

The fourth Taegeuk form – signifies Thunder

Count 20-40 in Korean

What are the three rules of concentration?

1. Focus your eyes
2. Focus your mind
3. Focus your body

What are three ways to have enthusiasm at Taekwondo?

1. Cheer on others for their efforts
2. Kihap loudly and energetically
3. Have a positive attitude about anything I do

## Purple Belt Self Defense Curriculum *\*\* (Adults Only)*

1. Collar Grab
  - A) Rotate the wrist 180 degrees (thumbs down), bend the elbow into a “S” figure, then rotate the hand toward the opponent and apply downward pressure to wrist
  - B) Twist 90 degrees, press arm to chest, step back with right foot, strike perpendicular with the forearm downwards on the crook of the elbow joint, leading the opponent to the floor
2. Choke Hold
  - A) Finger jab below the Adam’s Apple in the “hollow” space in the neck
  - B) Palm strike under one elbow going upwards, simultaneously strike the other arm down on the center of the elbow joint, and rotate the arms in a circle