

# **BELT TEST REQUIREMENTS**

## **Orange Belt**

1. FORM: “Taegeuk Yi Jang”
2. KICKS: Fighting Stance
  - A) Push Kick
  - B) Back Kick
  - C) Hook Kick
  - D) Spinning Hook Kick
3. SAM BO GYORUGY 1-4 (3 STEP SPARRING) *\*\* (Adults only)*
  - 1 Step back with right foot/left hand knife hand block  
Step back with left foot/right hand knife hand block  
Move right foot out to a horse riding stance/left hand knife block/right hand middle punch at the same time
  - 2 Step back with right foot/left hand knife hand block  
Step back with left foot/right hand knife hand block  
Move right foot out to a horse riding stance/left hand knife block/right hand neck strike  
Move right foot to left foot/grab opponent’s right wrist with left hand/reverse neck strike with right hand
  - 3 Step back with right foot/left hand knife hand block  
Step back with left foot/right hand knife hand block  
Step back with left foot/right foot sidekick to opponent’s middle
  - 4 Step back with right foot/left hand knife hand block  
Step back with left foot/right hand knife hand block  
Right arm middle inner block/right elbow strike to opponent’s ribs
4. JAIU GYORUGY (FREE SPARRING)
5. BOARD BREAKING: Side kick or Push Kick
6. ALL PREVIOUS BELT TEST REQUIREMENTS (WHITE & YELLOW)
7. QUESTIONS: All information given on the white - orange belt question sheets

# Tae Geuk Yi Jang

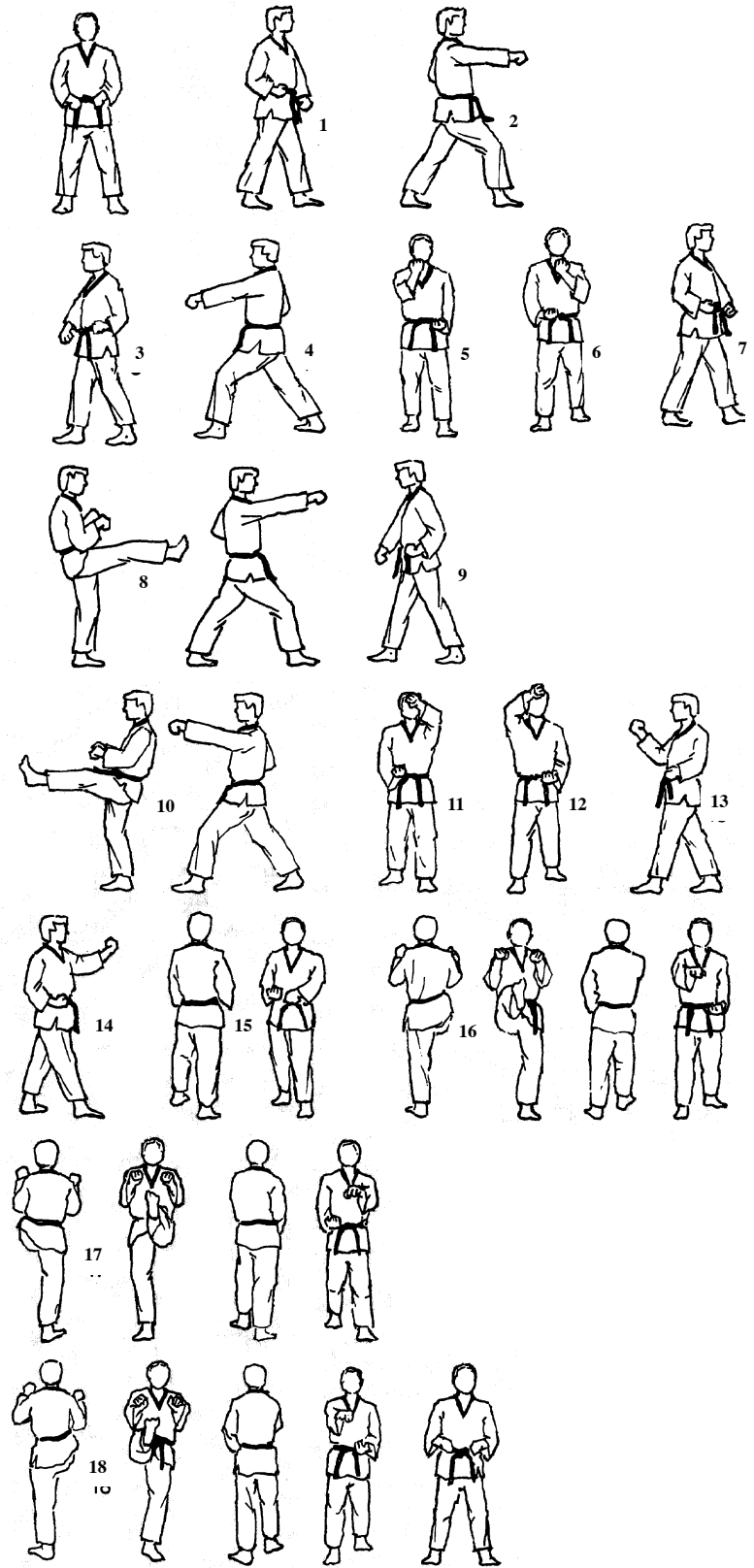
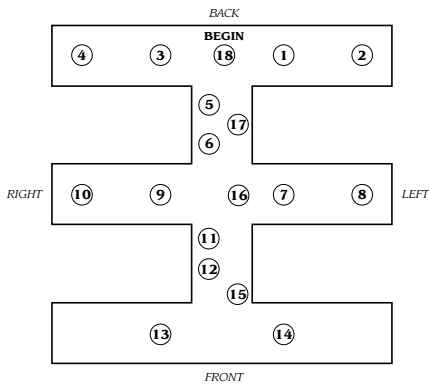

## **Orange Belt Questions**

1. What is the meaning of the orange belt?  
The orange belt signifies sunset – promise of more opportunities tomorrow.
2. What is the meaning of Taegeuk Yi Jang?  
The second Taegeuk form – signifies Joy
3. Why do we practice controlled free sparring?  
To demonstrate mental discipline  
To show physical control over ourselves  
To build self-confidence which indicates a strong mind, SIR!
4. How do you count 11-20 in Korean?  
Eleven – “Yul Hana”  
Twelve – “Yul Dule”  
Thirteen - “Yul Set”  
Fourteen – “Yul Net”  
Fifteen – “Yul Dasot”  
Sixteen – “Yul Yasot”  
Seventeen – “Yul Il Gob”  
Eighteen – “Yul Yo Dule”  
Nineteen – “Yul Ahop”  
Twenty – “Sumul”

## **Orange Belt Self Defense Curriculum (Adults Only)**

1. Straight Arm Wrist Grab
  - A) Outer-circle rotation, bend the wrist, then move into an arm bar
  - B) Inner-circle rotation, pull away the thumb, and use both hands to twist the opponent’s hand and wrist
2. Double Wrist Hand Grab
  - A) Raise the arms, follow up by a double elbow strike to forearms
  - B) Inner-circle rotation, to hand twist (similar to 1A)